

CHIEF'S SHOP PLAN OF THE WEEK



SIMPLE WOODWORKING: FIREPIT BENCH



WHAT YOU'LL NEED



LUMBER

2 - 2 x 4 x 8
1 - 2 x 4 x 10
1 - 2 x 6 x 8

(availability will vary)

HARDWARE/SUPPLIES

2 1/2" pocket hole screws
2 1/2" deck screws
wood glue
paint, stain, polyurethane,
or sealer

TOOLS

miter saw
sander/belt sander
drill/driver
Kreg pocket hole jig
clamps
square

ABOUT THESE PLANS

On this first page you will see above the project complete. On the [last page](#) you'll find the finished outer dimensions. Be sure to read ALL of the project steps before you start.

To the right is a list of the Lumber, Hardware/Supplies, and Tools you will need to complete this project. A measuring tape and pencil are not included because that should be pretty standard and self explanatory.

Below What You'll Need is the Parts list. This also is included on the [Cutting Diagram](#) page, which is the next to last page of this plan document. Also on the [Cutting Diagram](#) page is an estimate of the cost of the lumber. This estimate doesn't include any other supplies and does not factor in sales tax.

Throughout these plans you'll find the icons below:



LAYOUT

This indicates a diagram detailing the dimensions of a project part and/or the placement for pocket holes, screws, nails, etc.



NOTE

Notes are the instructions for a particular step/section of the project.



TAKE CARE!

This indicates when to pay close attention to the diagrams, take precautions for safety, etc.



MORE PLANS

Want more Chief's Shop plans? Visit chiefs-shop.com and look through the Plans section.

Be sure to "Like" Chief's Shop on facebook by heading over to [facebook.com/ChiefsShop](https://www.facebook.com/ChiefsShop).

PARTS

Inside Legs (4) - 1 1/2 x 3 1/2 x 14
Outside Legs (4) - 1 1/2 x 3 1/2 x 17
End Rails (2) - 1 1/2 x 3 1/2 x 16
Side Rails (2) - 1 1/2 x 3 1/2 x 39
Stretcher (1) - 1 1/2 x 3 1/2 x 13
Wide Seat Slats (2) - 1 1/2 x 5 1/2 x 47 3/4
Narrow Seat Slat (1) - 1 1/2 x 3 1/2 x 47 3/4

All parts are listed in actual dimensions. Refer to the Cutting Diagram on the last page of this plan as a guide for determining the specific board from which to cut the parts.

VIDEO

Check out Chief's Shop Videos on YouTube. ([click here](#))



Apply glue to one face of the Inside Leg, position flush with one end of the Outside Leg, clamp in place and attach using three 2 1/2" deck screws. Position the screw at the flush end more than 1 1/2 inches from the end. Make four assemblies.

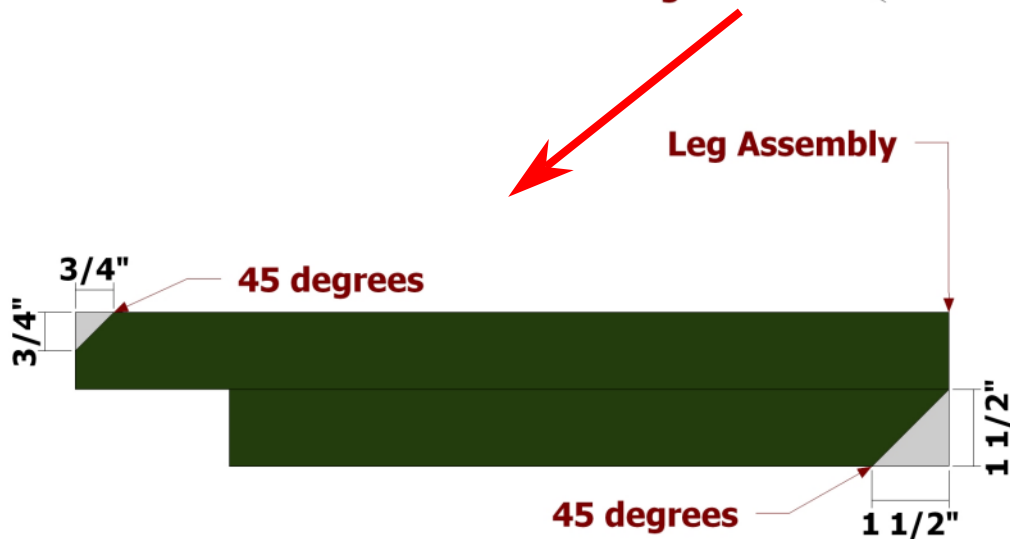
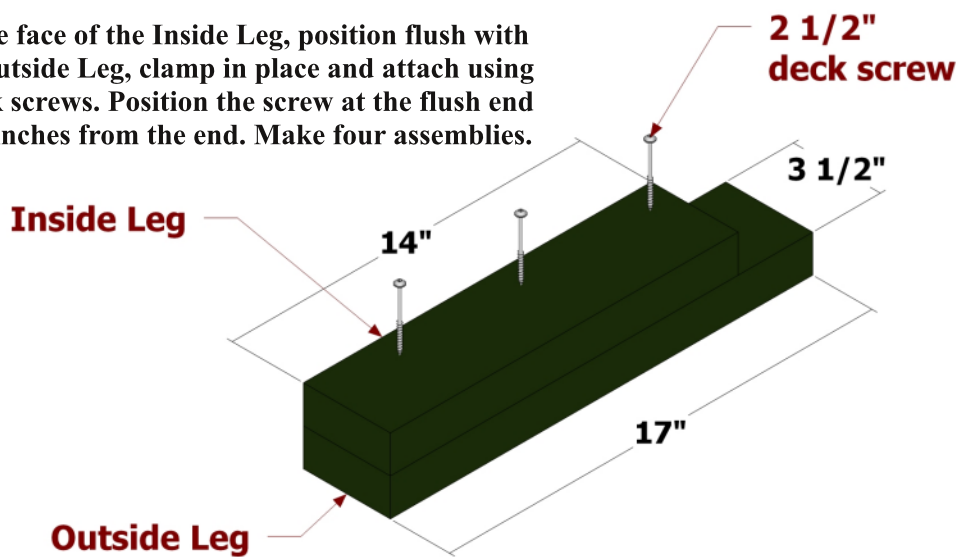

Position the Leg Assembly on its edge on your miter saw, and cut bevels on the ends as shown above. Repeat on all four assemblies.

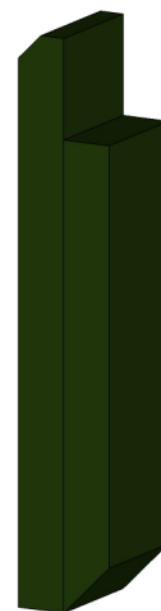

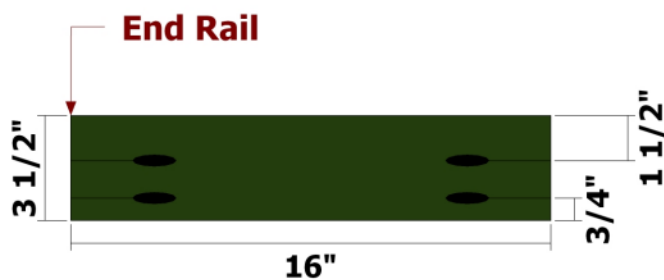

NOTE

Use the layout above for creating the End Rails. Set your Kreg Jig and drill bit for 1 1/2" stock.



NOTE

Position the parts as shown below and attach using glue and 2 1/2" pocket hole screws. Create two End Assemblies.

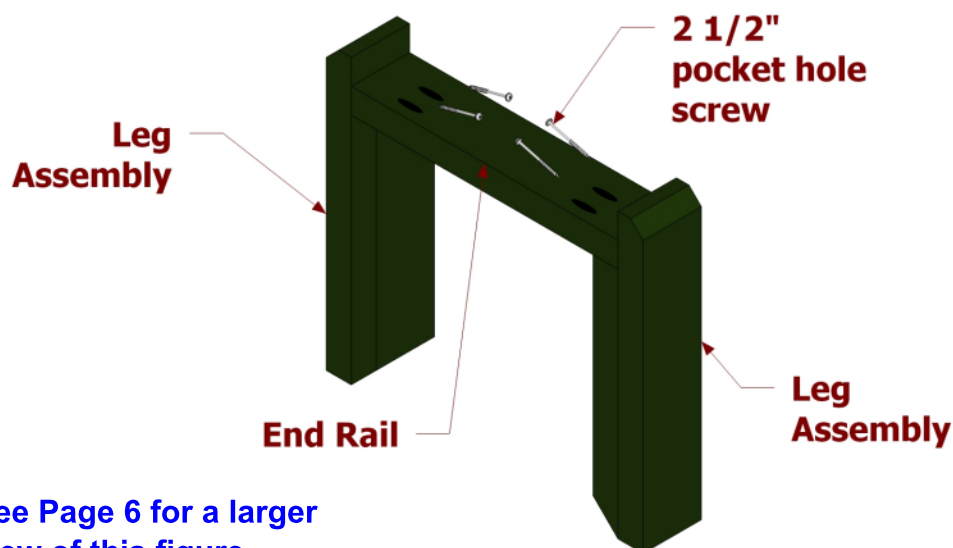

See Page 6 for a larger view of this figure.

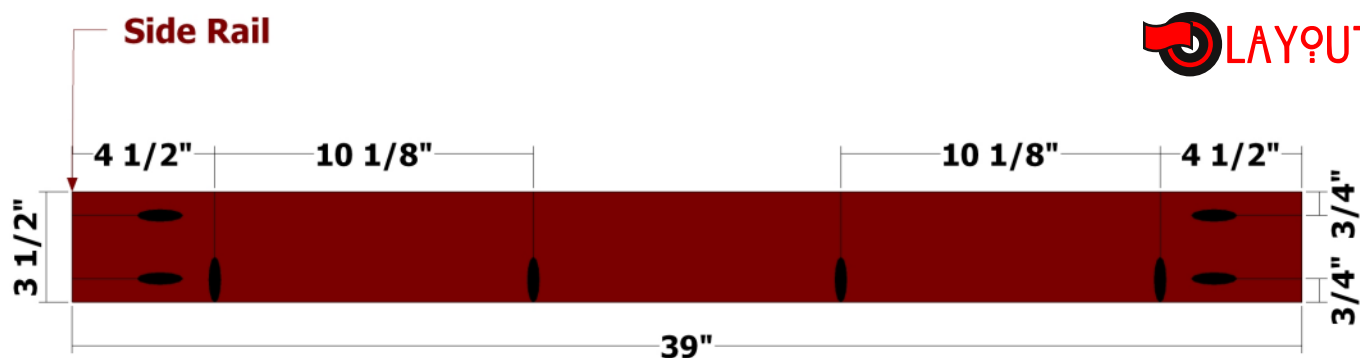

Use the layout above and below for creating the Side Rails and Stretcher. Set your Kreg Jig and drill bit for 1 1/2" stock.

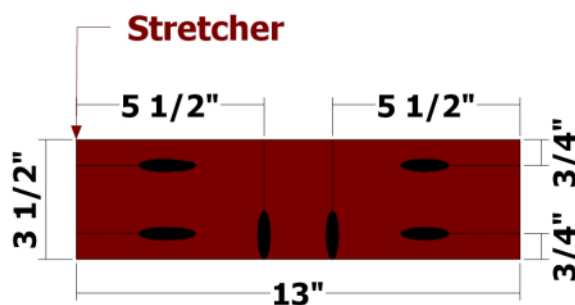

Position the parts as shown below and attach using glue and 2 1/2" pocket hole screws.

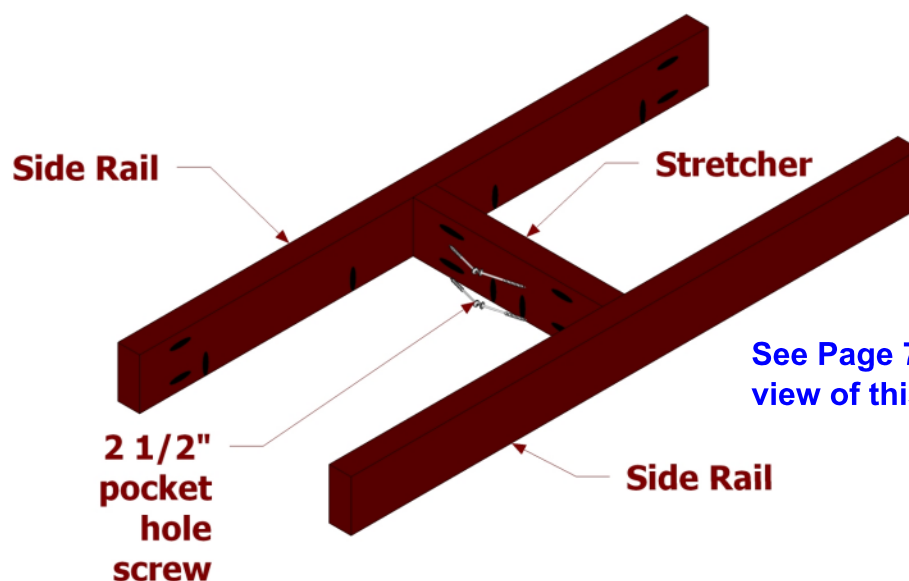

See Page 7 for a larger view of this figure.



NOTE

Position the parts as shown at right and attach using glue and 2 1/2" pocket hole screws. Use spacers cut from 2x4 scrap as shown to position the parts.

See Page 8 for a larger view of this figure.

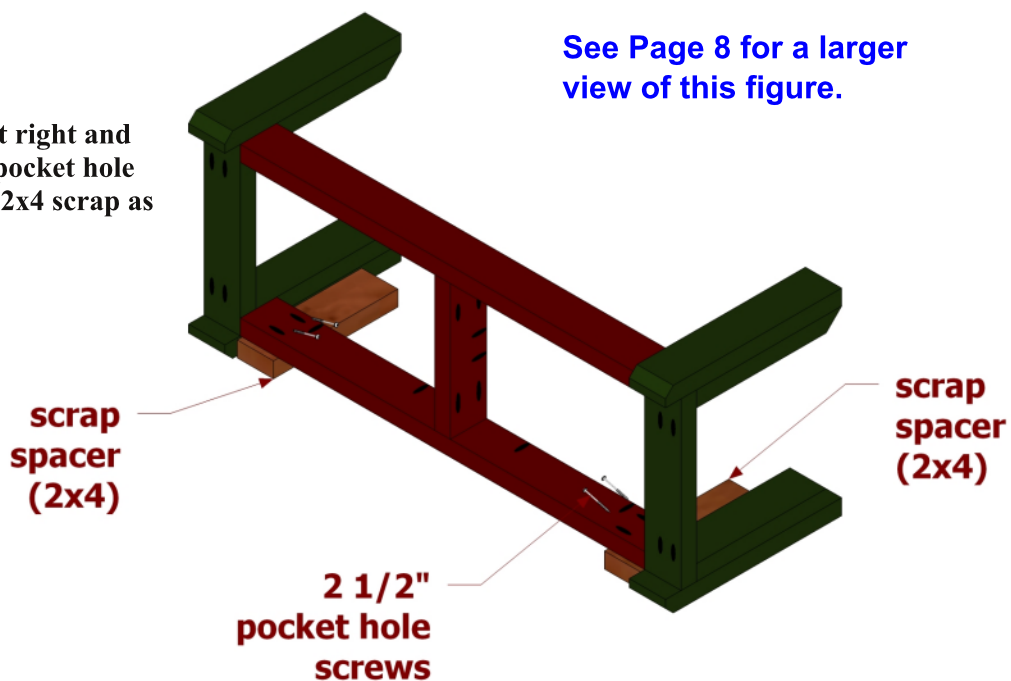

NOTE

Position the parts as shown below and attach using glue and 2 1/2" pocket hole screws at the Side Rails and Stretcher. Use glue and 2 1/2" deck screws or 2 1/2" pocket hole screws at the End Rails.

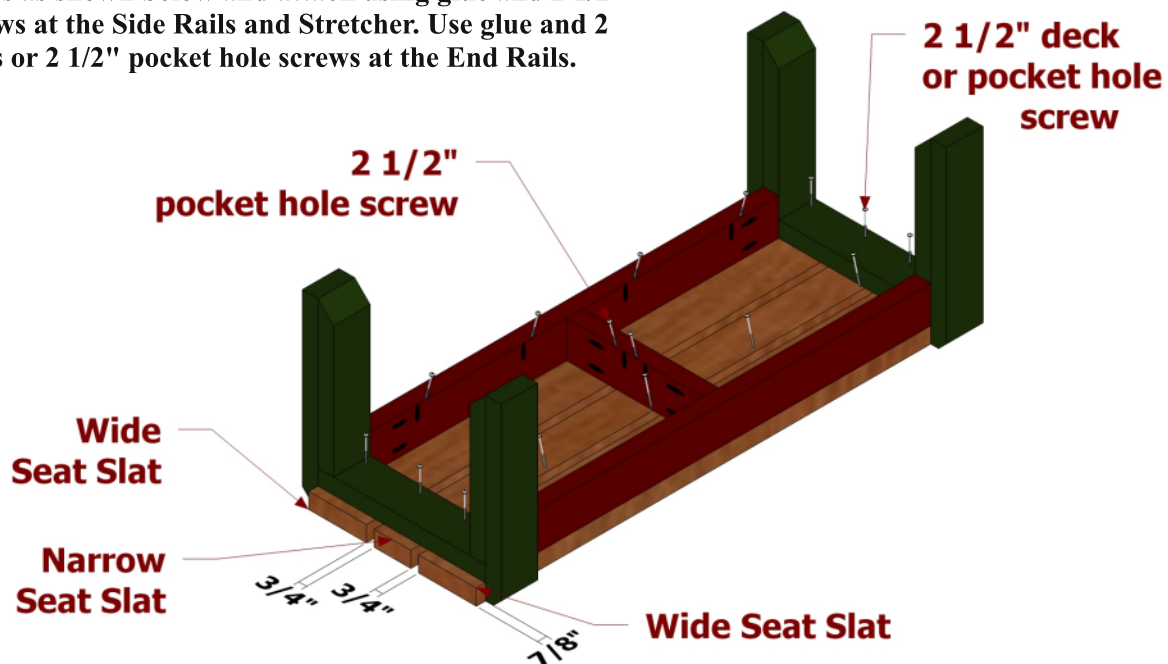

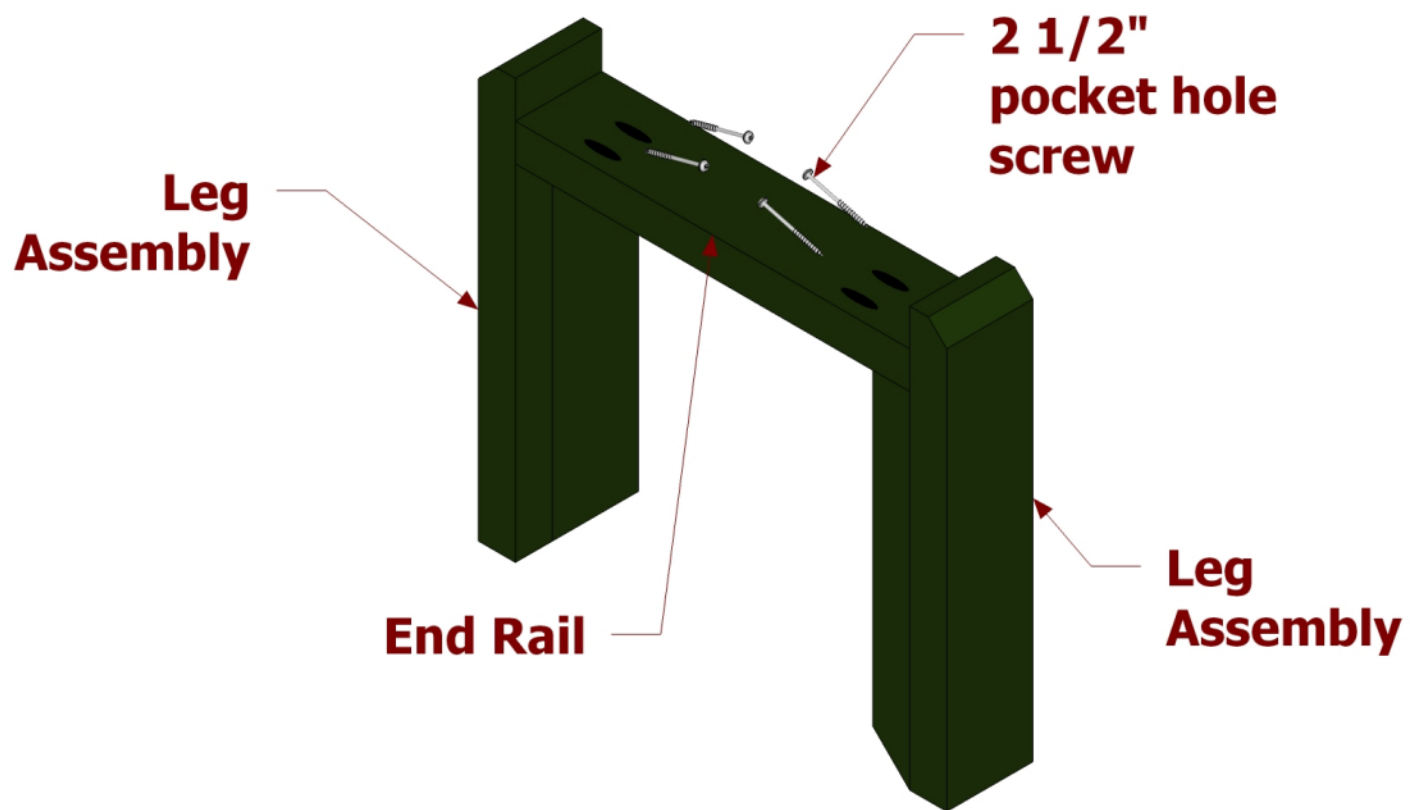

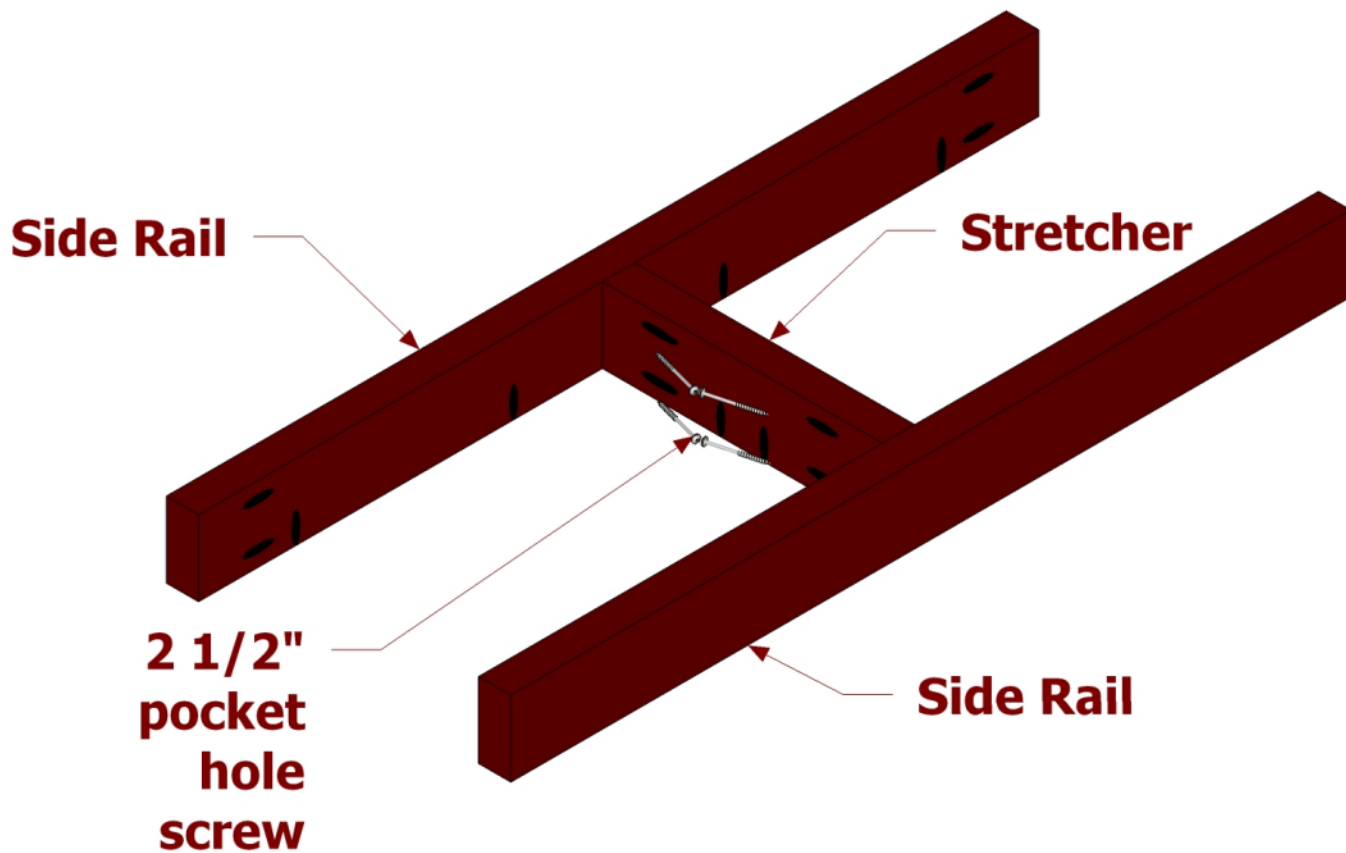

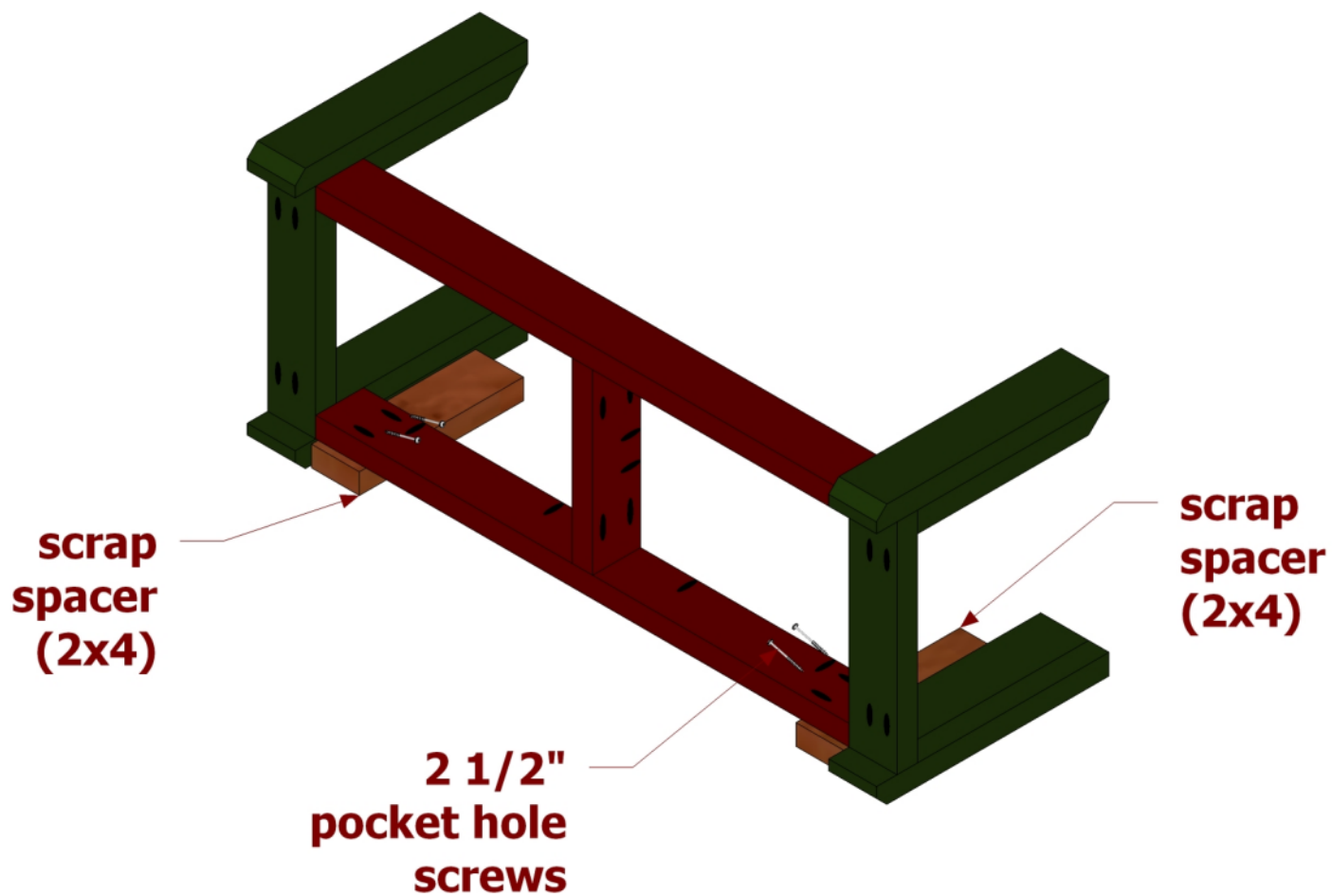

 **CUTTING DIAGRAM**

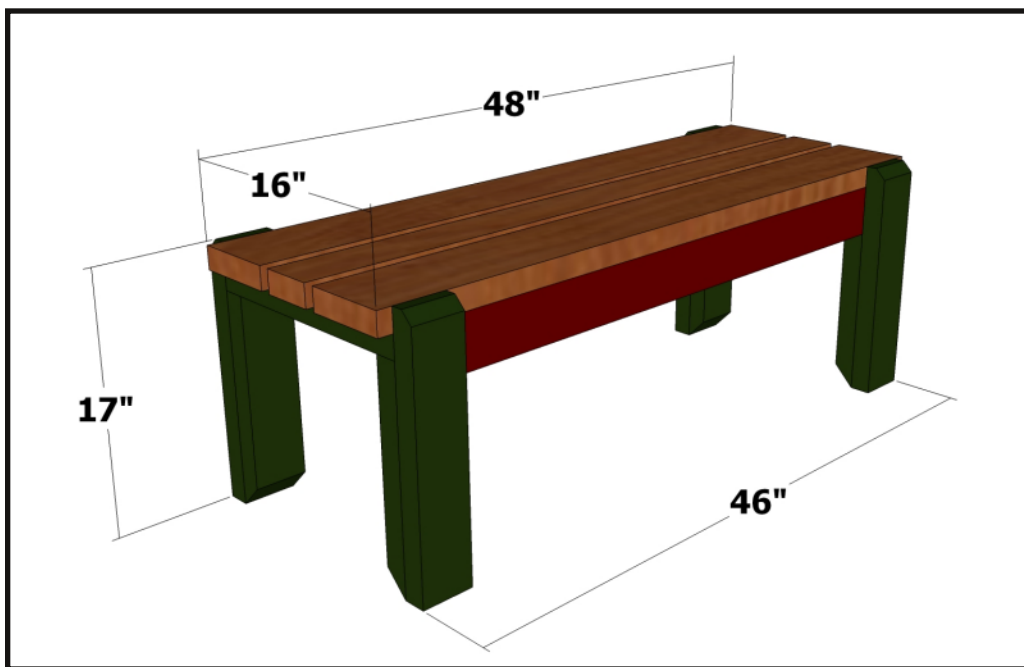
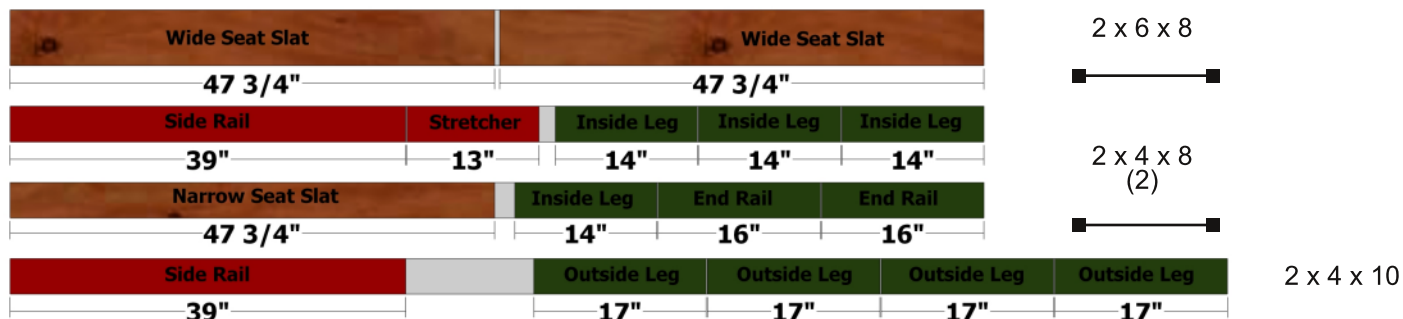

 **PARTS** 

- Inside Legs (4) - 1 1/2 x 3 1/2 x 14
- Outside Legs (4) - 1 1/2 x 3 1/2 x 17
- End Rails (2) - 1 1/2 x 3 1/2 x 16
- Side Rails (2) - 1 1/2 x 3 1/2 x 39
- Stretcher (1) - 1 1/2 x 3 1/2 x 13
- Wide Seat Slats (2) - 1 1/2 x 5 1/2 x 47 3/4
- Narrow Seat Slat (1) - 1 1/2 x 3 1/2 x 47 3/4

All parts are listed in actual dimensions. Refer to the Cutting Diagram on the last page of this plan as a guide for determining the specific board from which to cut the parts.

 **TAKE CARE!**

Follow ALL SAFETY GUIDELINES AND RECOMMENDATIONS provided by the manufacturers of your tools, and any chemicals such as glue and finishes you use in this project. YOU are responsible for your safety, so use common sense when working in the shop!